

Intuitive Screens: Lead the operator through the set up and monitoring of the test procedure.

PCTB Electronic "PLC" Series Test Benches

Operators Manual

Including PCTB-1500PLC, PCTB-2500PLC, PCTB-3500PLC and PCTB-4000PLC

Safety Precautions



SAFETY PRECAUTIONS



- READ INSTRUCTIONS AND IDENTIFY ALL COMPONENT PARTS BEFORE OPERATING BENCH.
- TEST BENCH PRODUCES EXTREMELY HIGH PRESSURE. USE CAUTION WHEN OPERATING.
- KEEP BOTH HANDS AWAY FROM PINCH POINTS.
- CONSULT HOSE AND FITTING MANUFACTURER'S SPECIFICATIONS FOR CORRECT TESTING PROCEDURE.
- ALWAYS WEAR EYE PROTECTION.

MODELS COVERED

This manual is applicable to different variations of the Manual Test Benches Series PCTB-1500PLC, PCTB-2500PLC, PCTB-3500PLC and PCTB-4000PLC the procedures are similar for the models.

Equipment Warning

Proper assembly of Continental hose and fittings

Continental hose, fittings and crimping equipment work together to provide an efficient and reliable hose connection. Continental hose and fittings are part of an engineered system and are to be used in accordance with Continental specifications. Using non-Continental components may produce an assembly that does not meet rated performance. **Continental does not warrant, expressly or by implication, hose assemblies that do not incorporate Continental hose and fittings, or are not crimped in accordance with Continental process specifications.**

Buyers may elect to attach additional or non-standard parts or equipment, or to use different manufacturing specifications as necessary to meet the requirements of the buyer or the customer's application. In such cases, the buyer has sole responsibility to qualify the hose for the applications as necessary to ensure performance capability.

For guidance in the assembly of Continental hose and couplings, please refer to the Continental Crimp Specifications Manual. Information in this manual is believed to be accurate, but is not warranted and is subject to change without prior notice. For the most current product information, check the Continental website at www.continental-industry.com For technical assistance, please contact your Continental representative at 1-800-235-4632.

Table Of Content

SAFETY PRECAUTIONS-----	2
COMPONENT PARTS IDENTIFICATION-----	4
TECHNICAL DATA-----	5
FEATURES-----	6
TEST BENCH CONNECTIONS / OPERATION-----	7
TEST PROCEDURE-----	9
DATA LOG OPTION-----	10
INFORMATIONAL TEST SCREENS-----	11
ADJUST THE PRESSURE RELEASE VALVE (DIAGRAM)-----	12
ADJUST THE PRESSURE RELEASE VALVE PROCEDURE-----	13
REPLACEMENT PARTS-----	15
CONTINENTAL CONTACT INFORMATION-----	17

Component Parts Identification

Whether you are producing a single assembly or a production run, Continental has the test equipment to give both you and your customer the assurance that the product has been assembled correctly. A programmable PLC Controller gives the operator the ability to pre-program and repeat a test sequence and print the results on the attached tape (optional save to USB).

CUSTOMIZED AND SPECIAL DESIGN BENCHES

In addition to the standard Electronic "PLC" series test benches: PCTB-1500PLC, PCTB-2500PLC, PCTB-3500PLC and PCTB-4000PLC special purpose test benches can be designed by our engineering department, as well as an extension trough can be designed to meet specific requirements.

Control Panel

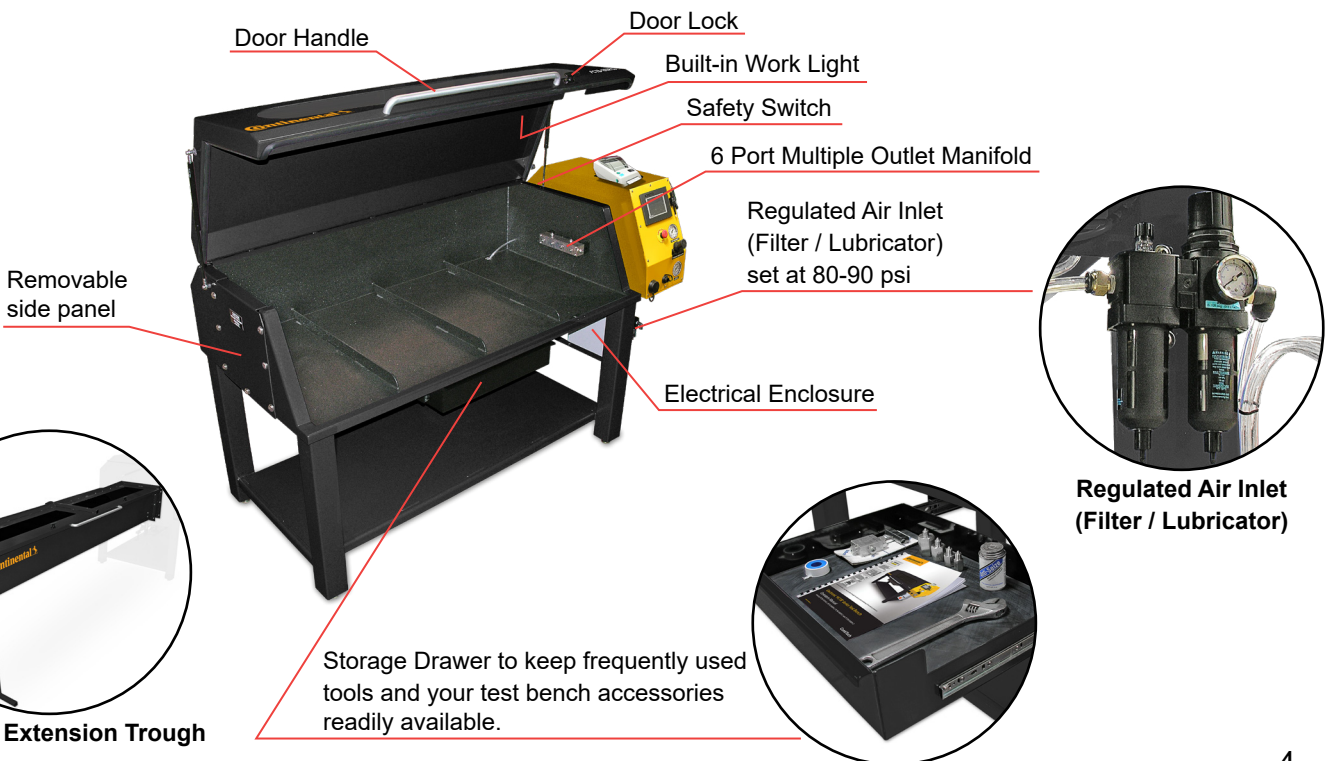
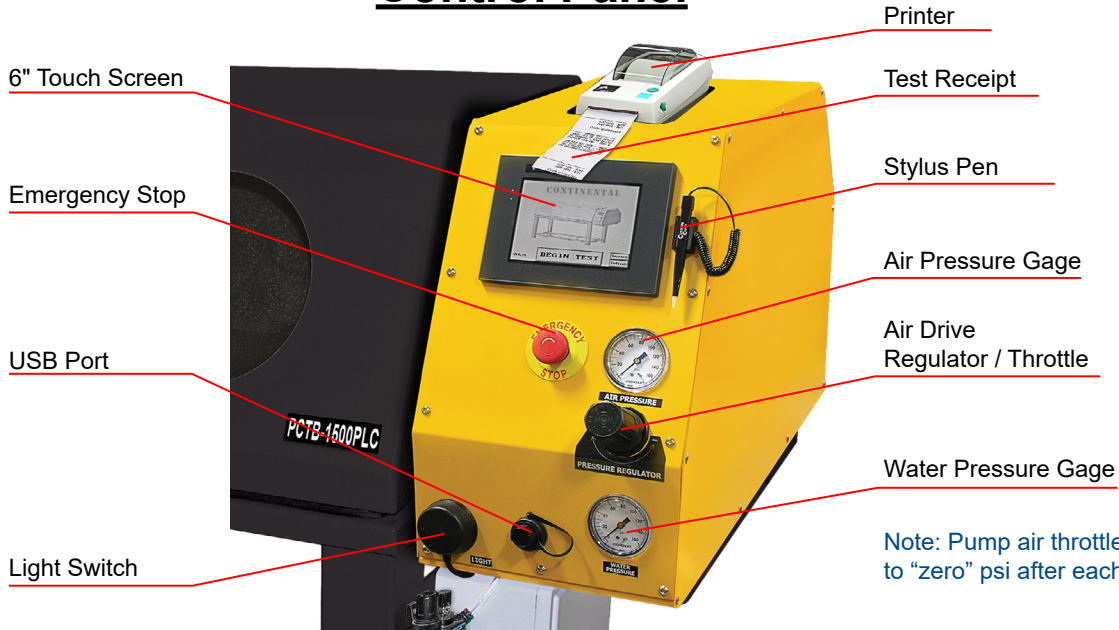

Technical Data



TECHNICAL DATA	PCTB-1500PLC	PCTB-2500PLC	PCTB-3500PLC	PCTB-4000PLC
Inside cabinet dimensions	L: 67" x W: 33" x H: 17"			
Overall dimensions	L: 85" x W: 39" x H: 78" (Closed H: 52")			
Weight	955 lbs			
Maximum pressure	21,750 PSI	36,250 PSI	50,750 PSI	60,000 PSI
Low pressure	5,000 PSI			

Features

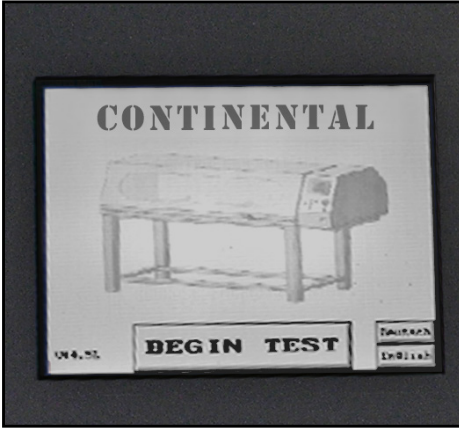

6" touch screen and user friendly navigation. Intuitive Screens lead the operator through the setup and test execution process.



Safety Switch activates and drops pressure as soon as the lid is opened.

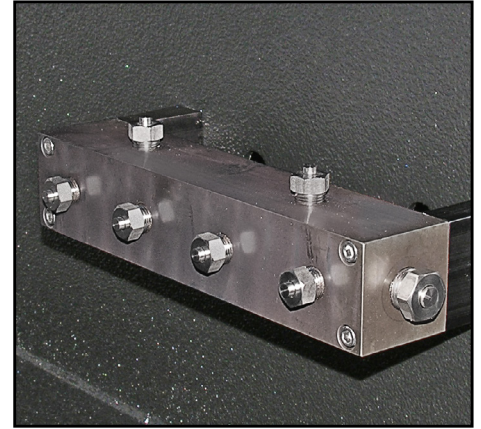

Multi-Port Manifold Outlet, allows multiple hose assemblies to be tested at the same time.



Results of each test are recorded and can be printed on the included printer or saved via USB port.



Removable side panel permits the testing of longer hose assemblies with the attachment of an optional trough.



Available extension trough in 10 foot sections.



Large capacity cabinet and fork truck accessible chamber make testing large hoses easy.



Storage Drawer to keep frequently used tools and your test bench accessories readily available.



Built-in work light to facilitate to see the hose being tested.

Test Bench Connections / Operation

TEST BENCH CONNECTIONS:

- Connect a water source (standard garden hose connection) to the water inlet connection located at the rear of the control cabinet.

Note: Water supply pressure should not exceed 100 psi. If a water pressure booster pump is on the tester, the water pressure should not exceed 50 psi. Damage to the booster pump can occur and can lead to water leaks that can be fairly significant.

- Connect a water drain hose (standard garden hose connection or barbed fitting) to the water drain connection located at the rear of the test cabinet. Run the drain to an appropriate drainage area.

- Connect an air supply of no more than 90 psi to the air inlet. Make sure the air lubricator is filled with oil. This must be checked periodically to assure proper operation of the pump. (Drip rate: 1 drip per 20 pump cycles).

Note: Air pressure greater than 90 psi can damage vital equipment on the tester.

- Plug in electrical cord to a standard 15 amp 110VAC outlet.

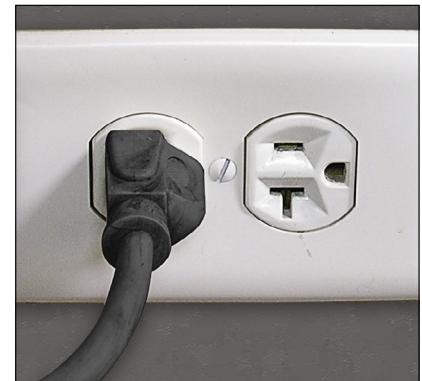
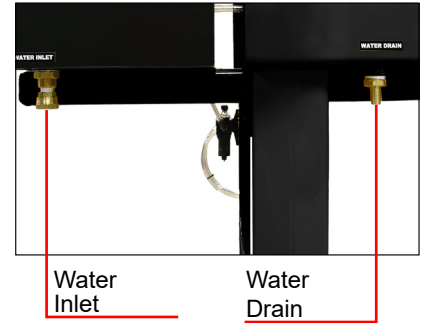

TEST BENCH OPERATIONS:

- Prior to operating the bench, make sure that the pressure regulator (throttle) knob is adjusted all the way out (counterclockwise). The air pressure gauge on the front of the control cabinet should read 0 psi.

- Follow the screen prompts to input the desired test parameters.



Test Bench Connections / Operation

- Raise the tank lid and connect hose to the tested to the manifold block.

Note: The manifold block standardly has 6 useable ports, 4 on the main face and 2 along the top. The ports are standard with either HF4 (High Pressure) or LM9 (Medium-Low Pressure) connections. These are cone and seat style connections.

- Secure any unused ports with the supplied plugs.
- Bleed the hose of air. Use the Fill Hose feature to fill the hose with water (or whatever fluid media is being used).

Note: This “Fill Hose” feature can be found on the **Review Parameters screen**, refer to test procedure page.

- While bleeding the hose, hold the opposite end of the hose higher than the manifold block. This forces the air out the end of the hose.

- Once a steady stream of water is exiting the end of the hose, either cap the end of the hose off or use the needle valve included to close the end of the hose.

- Place the supplied rubber mat over the hose(s). This will help contain the hose and ends if a hose failure occurs.

- Lower the tank lid and make sure the latch engages to ensure it is fully closed.

- Begin the test.

- Begin raising the air pressure regulator (Air Drive Throttle) until the desired test pressure has been achieved.

Note: The high pressure pump is driven by air pressure. As the air pressure is increased using the regulator (throttle), the water pressure will increase. The more air pressure supplied, the higher the test pressure.

- When the test cycle is complete, check over the test result page and print the test receipt if desired.

Note: Once the test result page has been passed, a test receipt can no longer be printed.

- Open the cabinet lid and remove the hose(s).

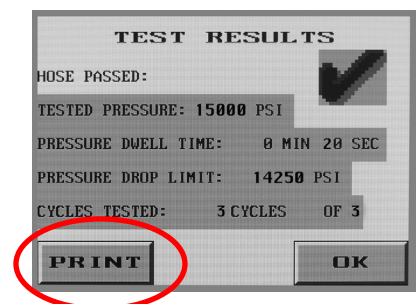
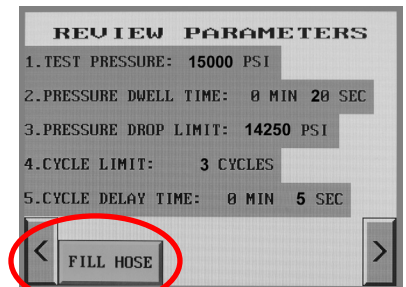
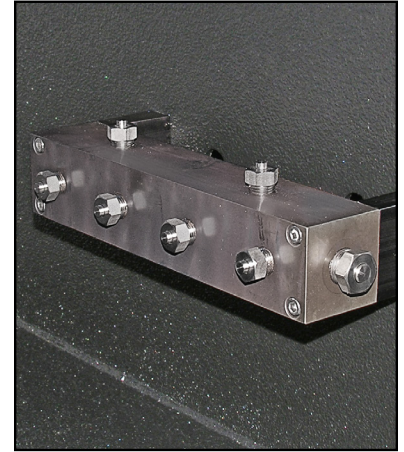

Test Procedure



After the system initializes and loads, the “Begin Test” screen will appear.



Press New Test to initiate a test or Repeat Test to repeat the previous test.

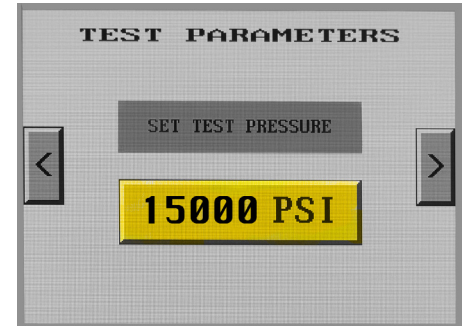

Press the pressure button to bring up the pressure adjustment keypad screen.

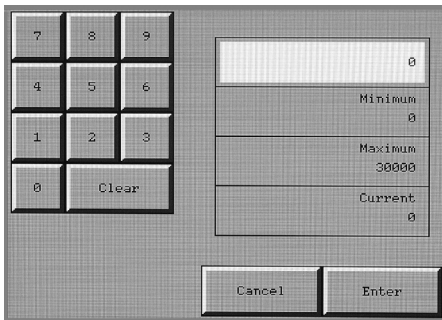

Enter the max test pressure. Keypads will pop up for settings not indicated by arrows as shown on the next screen.

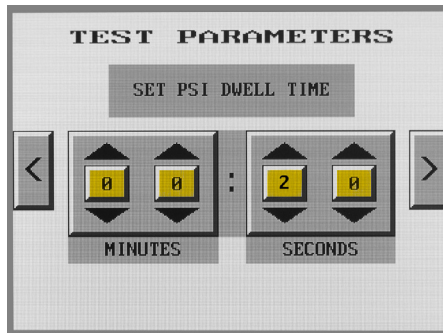

Set the time for the hose to be held at test pressure.

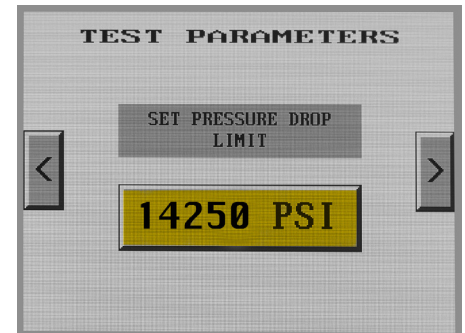

Enter the minimum pressure allowed during the test cycle.

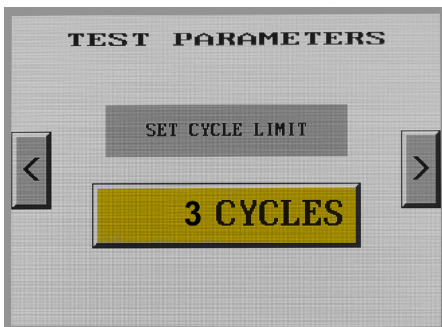

Enter the number of times that the test is to be run.

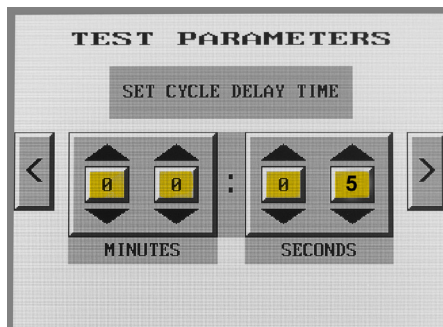

Enter the delay time between test cycles.

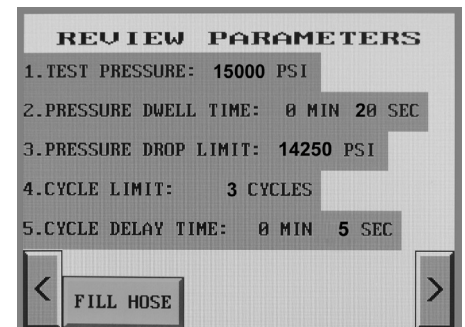

Review test parameters prior to running test.



If test parameters and test setup is correct, start test.

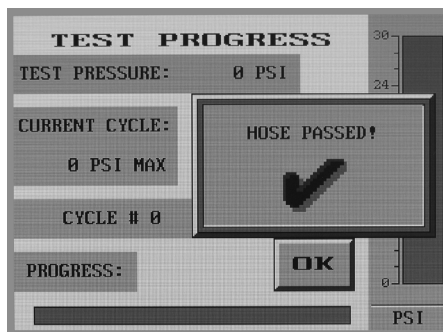

Test progress is shown.

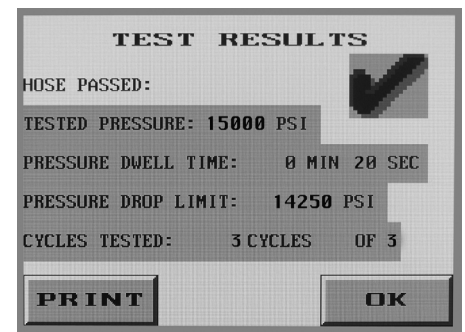

Test results are shown and the print option is available.

Data Log Option



From the main screen, select Options.

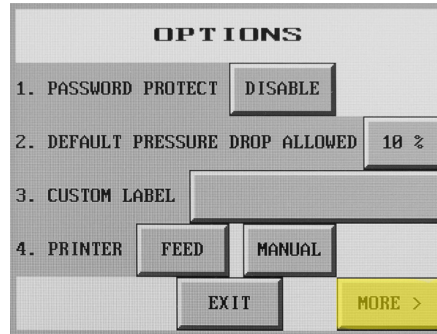

Select More from the Options menu.

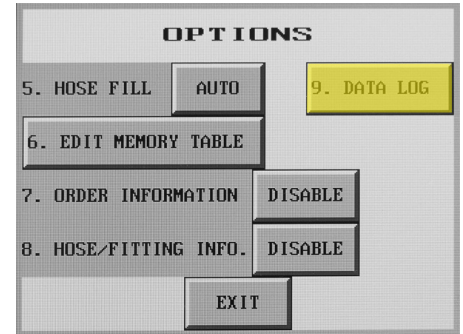

Select Data Log from the second Options screen.



Following instructions on the screen, Install Flash Drive.



Press Start Transfer once the unit is ready. (Screen will flash briefly)



Select Remove USB once transfer completes. Exit and remove Flash Drive from control panel.

	A	B	C	D	E	F	G	H	I	J	K	L
1	Date	ORDER #	TEST PSI	CURRENT DWELL -	NDWELL -	SCURRENT	PSI DROP	CYCLE C	CYCLE L	DELAY -	N	DELA
2	6/3/2010 9:53	12368	1000	1036	0	10	1000	900	0	5	0	0
3	6/3/2010 9:53	12368	1000	1216	0	10	1168	900	1	5	0	0
4	6/3/2010 9:53	12368	1000	1165	0	10	1122	900	3	5	0	0
5	6/3/2010 9:53	12368	1000	1102	0	10	1064	900	3	5	0	0
6	6/3/2010 9:54	12368	1000	1079	0	10	1026	900	4	5	0	0
7	6/3/2010 9:54	132	1500	1541	0	10	1501	1350	0	2	0	0
8	6/3/2010 9:55	132	1500	1546	0	10	1500	1350	1	2	0	0
9	6/3/2010 9:59	658	2000	2095	0	10	2037	1800	1	10	0	0
10	6/3/2010 9:59	658	2000	2087	0	10	2024	1800	3	10	0	0
11	6/3/2010 10:00	658	2000	2115	0	10	2060	1800	5	10	0	0
12	6/3/2010 10:00	658	2000	2109	0	10	2046	1800	7	10	0	0
13	6/3/2010 10:00	658	2000	2095	0	10	2019	1800	9	10	0	0
14	6/3/2010 10:01	658	850	1140	0	10	1090	765	0	10	0	0
15	6/3/2010 10:01	658	850	1111	0	10	1077	765	1	10	0	0
16	6/3/2010 10:02	658	850	938	0	10	893	765	2	10	0	0
17	6/3/2010 10:02	658	850	887	0	10	858	765	3	10	0	0
18	6/3/2010 10:08	9453	600	713	0	4	671	540	0	10	0	0
19	6/3/2010 10:08	9453	600	687	0	4	639	540	1	10	0	0
20	6/3/2010 10:08	9453	600	637	0	4	599	540	2	10	0	0
21	6/3/2010 10:08	9453	600	665	0	4	625	540	3	10	0	0
22	6/3/2010 10:08	9453	600	670	0	4	626	540	4	10	0	0
23	6/3/2010 10:08	9453	600	672	0	4	636	540	5	10	0	0
24	6/3/2010 10:08	9453	600	670	0	4	627	540	6	10	0	0

Log files will be saved on USB drive. Using a computer, locate the EA_LogCopy folder to view data. A separate file will be saved and labeled for each day. Information is most compatible with a program like Microsoft Excel. Test results will be stored and formatted as shown above.

Informational Test Screens

There are informational, adjustment and warning screens programmed into the software. While most are self explanatory, a brief description is given below.



If the test does not complete satisfactorily, the Hose Failed screen will appear.

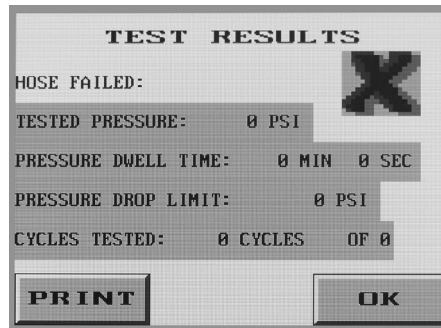

This screen details the cause of the failed test.

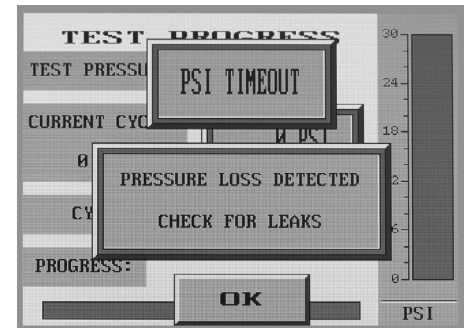

Test cycle was unable to finish due to pressure leaks.



Emergency stop is depressed.

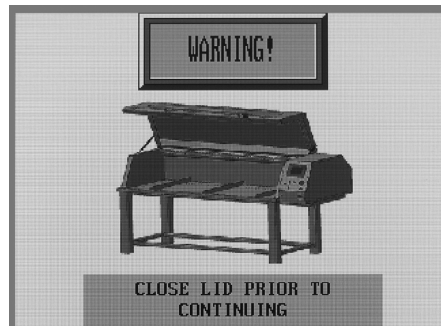

Test bench lid is not properly closed and latched.

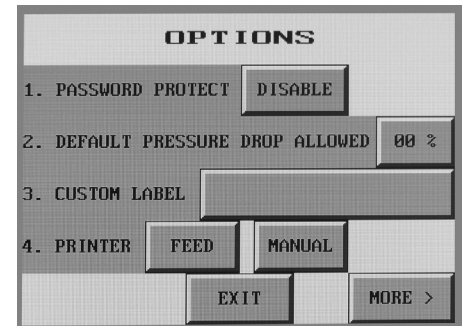

From the Main Menu Options screen, default parameters can be set.

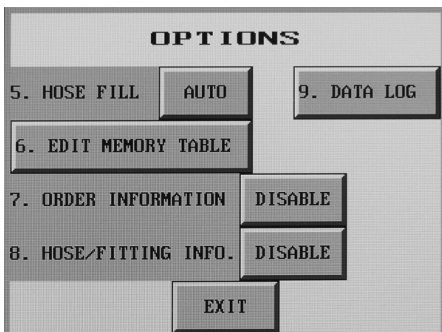

Access to the memory table and adjustments to the print tape can be found here.

Adjust The Pressure Release Valve

ADJUSTING THE PRESSURE RELEASE VALVE

(Refer as Hipco Valve)

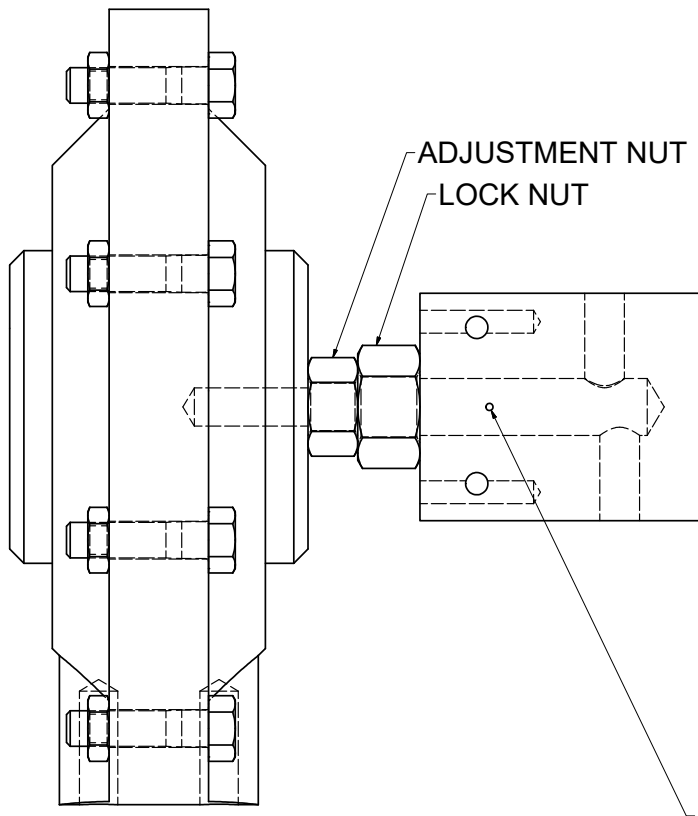

WEEP HOLE.
IF PACKING IS NOT
TIGHT ENOUGH, WATER
WILL COME OUT THIS HOLE.

- Follow the instructions on page 13-14.

Adjust The Pressure Release Valve

1). Disconnect the Air Line.

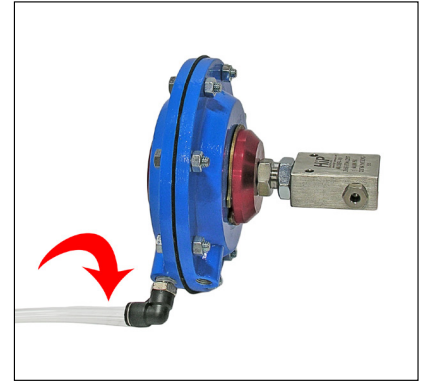

2). Use a 1" wrench to grab the Adjustment Nut and with a 1-1/8" wrench to loosen the Lock Nut, until spins freely.

(Adjustment Nut will be closest to Blue Diaphragm).



3). Rotate the Blue Diaphragm counter-clockwise to remove it from the Block.

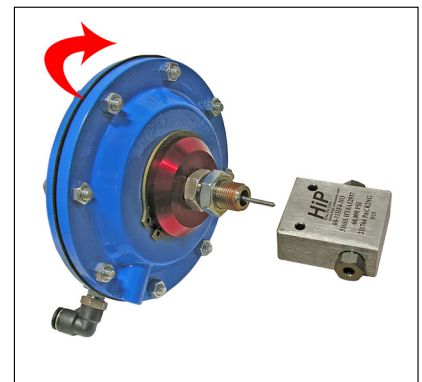

4). Clean the Blue Diaphragm Needle and apply grease. Remove the Packing from the block and clean them. Place the Packing on the Blue Diaphragm Needle.

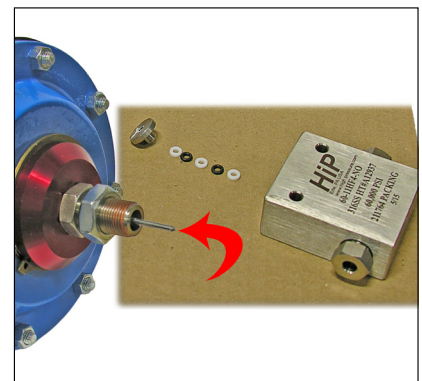

Adjust The Pressure Release Valve

- 5). The Packing must follow the order as shown.
Apply grease all over the packing.

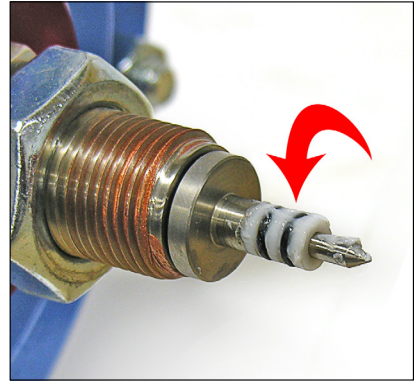
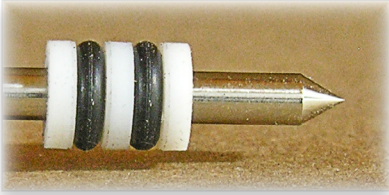

- 6). Place the Blue Diaphragm Needle (Packing installed) into the Block and rotate the Blue Diaphragm clockwise until you can feel the packing (Seals) make contact with the valve cone.

Note: Do not tighten past this point, damage to stem and packing can occur. Tightening past this point will begin to compress the packing and will also make the stem stick again.

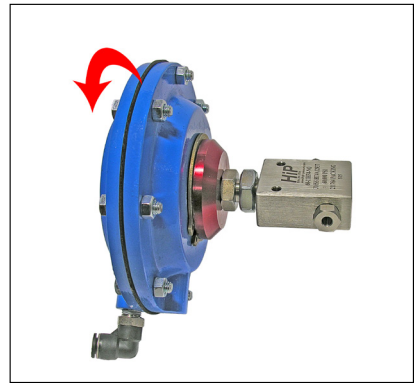

- 7). Use a 1 inch wrench to grab the Adjustment Nut and with a 1-1/8" wrench to tighten the Lock Nut. (Just snug tight).

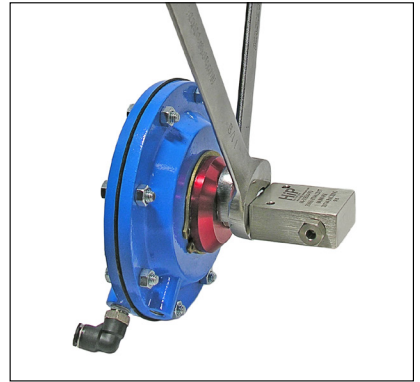

- 8). Reinstall in machine to check operation.
- Best to plug off manifold and test to a pressure.
 - If water comes out of weeping hole than go back to step 6 and snug stem slightly more.

Note: The objective is to tighten the Adjustment Nut so that the packing seals around the needle and still allows the Blue Diaphragm to move the needle back and forth to build pressure and drain.

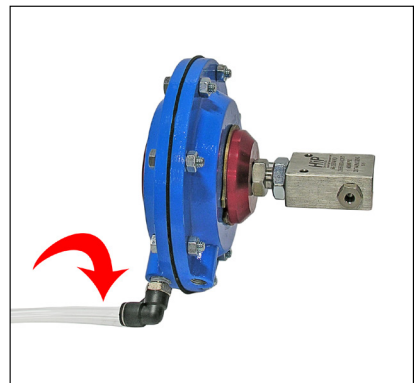

Replacement Parts



1/4" NPT P/N:103687-04



3/8" NPT P/N:103687-06



1/2" NPT P/N:103687-08



3/4" NPT P/N:103687-12

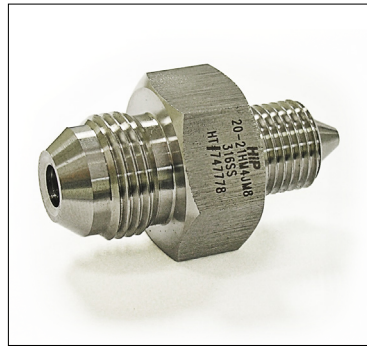

1/2" JIC P/N:104428-08

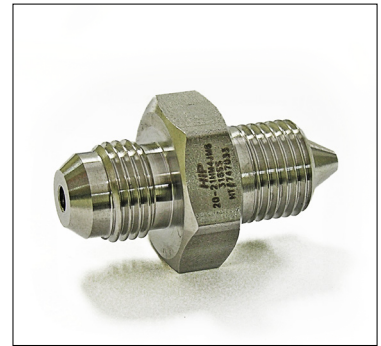

3/8" JIC P/N:104428-06



2WAY NEEDLE VALVE P/N:104352



5000 PSI RELIEF VALVE P/N:104642

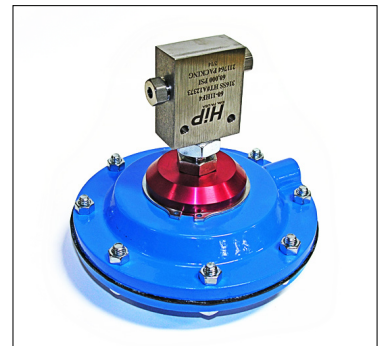

RELIEF VALVE P/N:104241



REPAIR SEALS P/N:104241-SEALS

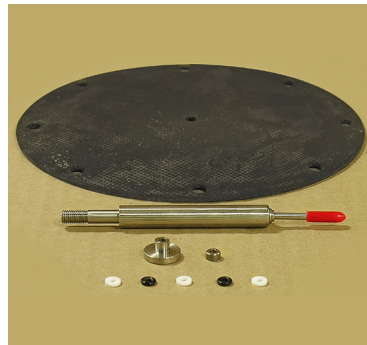

HIPCO 60K AIR VALVE REPAIR KIT P/N:104241-KIT

Replacement Parts



AIR REGULATOR P/N:104115



MANIFOLD BLOCK P/N:102100



PCTB-1500 PUMP P/N:103860



PCTB-2500 PUMP P/N:103861



PCTB-3500 PUMP P/N:103862

Industrial Fluid Solutions

Market segment
Hydraulic Hose

Contact
ContiTech
703 S. Cleveland Massillon Road
Fairlawn, OH 44333-3023 U.S.A.
1-800-235-4632
www.contitech.us

Your local contact
www.contitech.de/contactlocator

Canada
1-888-275-4397

Mexico
1-800-439-7373

Continental. Smart Solutions Beyond Rubber

The ContiTech division of the Continental Corporation is one of the world's leading industry specialists. As a technology partner, our name is synonymous with expertise in development and materials for components made of natural rubber and plastics and also in combination with other materials such as metal, fabrics or silicone. By integrating electronic components, we are also generating solutions for the future.

Beyond products, systems and services, we also provide holistic solutions and have a formative influence on the industrial infrastructure. We see digitalization and current trends as an opportunity to work with our customers to add sustainable value - for both sides and for good.

Rev: 02/27/2020